



Dewhurst US90 Jumbo Pushbutton

The US90 Jumbo Pushbutton is a classic square extra large button. The button was primarily designed for use in larger buildings such as hospitals, airports and shopping centres, where the sheet scale of the building necessitates a larger button. On call acceptance the large 30mm high tactile legend illuminates brightly and you have the choice of many colour options. The US90 Jumbo has an identical appearance to the standard US90 and so the two buttons can be used on faceplates together when appropriate.

Features & Benefits

- 30mm high tactile legend
- Matches standard US90 Compact 2 range
- A halo of light between the pressel and surround via a patented hidden recess encircles the pressel and illuminates the legend
- Legend & halo can be constantly illuminated at half intensity, switching to full intensity for indication of position or call acceptance
- Large range of pressel legends
- Matching range includes keyswitches, rocker switches and indicators
- Vandal resistant with stainless steel front
- Meets EN81-1/2, EN81-71 (Category 2), EN81-72, EN81-73, EN60529 (IP54)

Illumination, Finishes & Marking

- Wide range of colours for illumination including (non), red, yellow, green, blue and white
- Range of pressel finishes including brushed stainless, mirror stainless, brushed brass and mirror brass*
- Range of surround finishes and heights - chrome, brass, black - 4.5 and 7.0mm
- Single, dual and bicolour illumination
- A large range of legends in Helvetica Medium characters & symbols are available
- 30mm tactile, red or opal characters/symbols are formed during the moulding of the pressel body

* Standard pressels are a brushed stainless steel plate moulded with red or opal polycarbonate



Dimensions

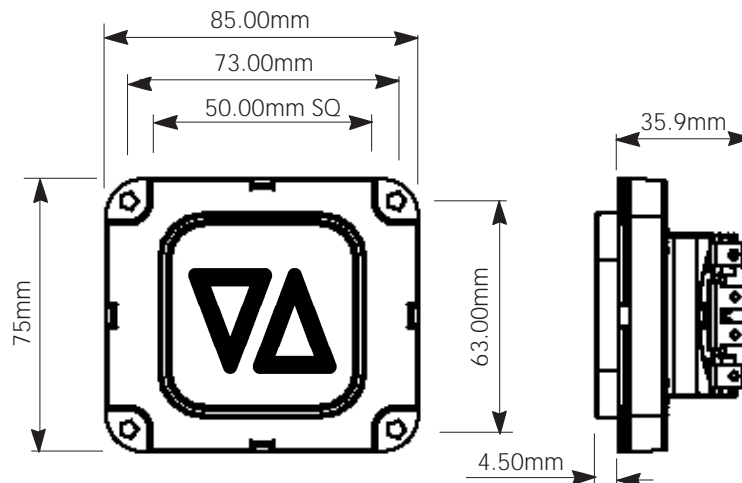

Jumbo Pushbuttons can be supplied loose or incorporated into stations with 1.5mm or 2.5mm stainless steel faceplates, with a vertical pitch of 80mm and horizontal pitch of 90mm i.e the pushbutton body can be rotated through 90 degrees (horizontal version shown above). If pushbuttons are supplied loose, spacers are provided to accommodate the differing faceplate thickness.

Technical Details

Weight:	150grms	
Moulded in:	High grade polycarbonate	
Pressel plate material:	Brushed 304 stainless (standard)	
Pressel plate area:	2500mm ²	
Button force:	3.5N	
Pushbutton size:	85mm w x 75mm h x 35.9mm d	
Pressel size:	50mm w x 50mm h x 4.5mm d	
Legend size:	30mm high, Helvetica medium characters	
LED current:	20mA (typically)	
LED voltage:	12/24/30/48/110V a.c./d.c. ±15%	
Operation:	Wiping action, slow make and break with solid silver contacts	
Ratings:	10 amps max	
	240V a.c. at 3.0 amps max. resistive loads	- min. no. of operations: 1 x 10 ⁶
	240V d.c. at 0.5 amps max. resistive loads	- min. no. of operations: 2 x 10 ⁶
	110V d.c. at 100mA max. inductive TC40m	- min. no. of operations: 1 x 10 ⁶
	12V d.c. at 5mA max. resistive loads	- min. no. of operations: 10 x 10 ⁶
Contact arrangements:	1 N/O standard - for other arrangements use relay/shunt boards as per data sheets PB129, PB134 and PB150 available on our website	
Code compliance:	Meets EN81-1/2, EN81-71(Category 2), EN81-72, EN81-73	
IP Rating:	EN60529 (IP54)	

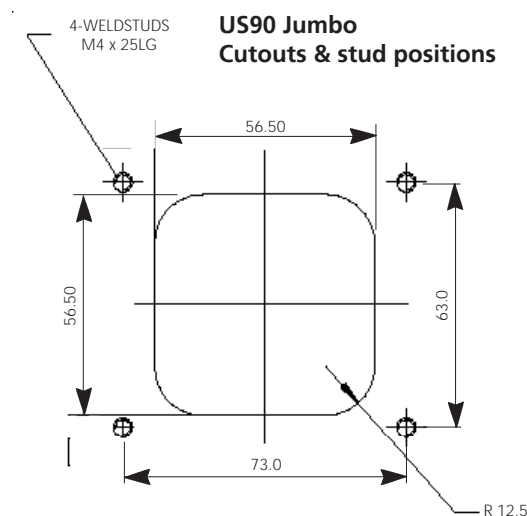
Cutouts & Stud Positions

Cleaning your US90 Jumbo

Many **Dewhurst** lift products are made of **polycarbonate** (Using GE's **Lexan**® or Bayer's **Makrolon**®).

The US90 Jumbo is highly durable and vandal resistant but the plastic parts can be damaged by aggressive cleaning agents, Dewhurst therefore recommends:



Clean the part with a **cotton cloth and warm water** before applying the cleaning product



Use **PH-neutral or slightly acid cleaning products only** (including aromatised ones) Ethylic alcohol, isopropyl alcohol or ethylene glycol based multipurpose cleaning products and dish soaps are suggested.



Dilute the cleaning product in warm water and apply using a wet cotton cloth.



Grease, glue and paint may be removed with ethylic alcohol or isopropyl alcohol.

Recommended Cleaning Products (*):

Europe	North America
Windus - Brial Top - Ecolab Mr. Proper Surfaces Delicates - Proctor & Gamble Palmolive, Colgate Palmolive	Formula 409® Cleaner Degreaser Joy®, Proctor & Gamble Windex, Drackett Products Palmolive, Colgate Palmolive

(*): Due to the vast number of cleaning products available on the market, the list of recommended products above is an illustration only

Note:

- Do not use abrasive cleaning agents
- Do not use sharp tools to remove dirt (chewing gum, glue, etc.)
- Do not use solvents based with Ketones, benzene, methanol, toluene (also known as methylbenzene or phenyl methane) or alkaline and ammonia based cleaning agents
- Do not use cleaning agents at high temperatures
- Do not leave cleaning agents on the parts for long periods: remove immediately after cleaning using a wet cotton cloth and warm water
- Do not use dry cotton cloths and sponges